

JIG VGZ 45°

INSTALLATION MANUAL

88 JIGVGZ45 01120

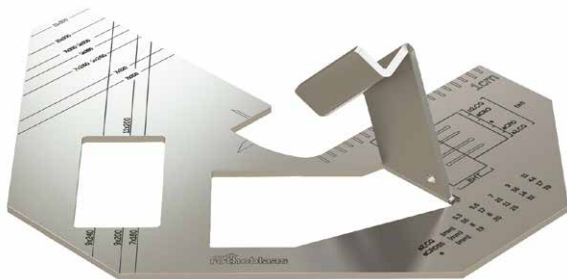

GEOMETRY

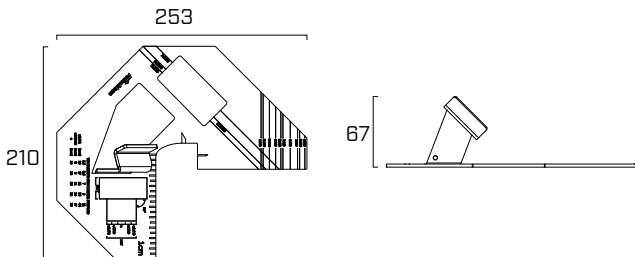

MINIMUM DISTANCES FOR CROSS SCREWS



SCREWS INSERTED WITH AND WITHOUT PRE-DRILLING HOLE

		5,3	5,6	7	9	11
$a_{2,CG}$	[mm]	21	22	21	36	44
a_{CROSS}	[mm]	8	8	11	14	17
e	[mm]	19	20	25	32	39

Recommended pre-drilling hole for connectors $\varnothing 11$ L ≥ 400 mm

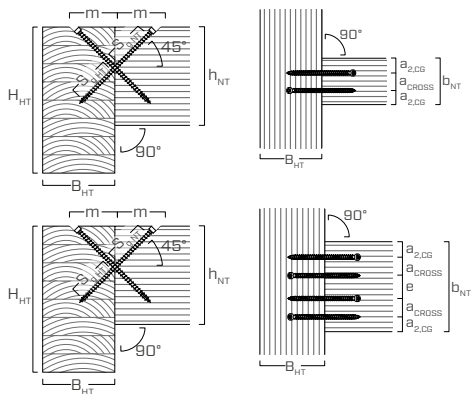

■ SCREW TIP POSITIONING

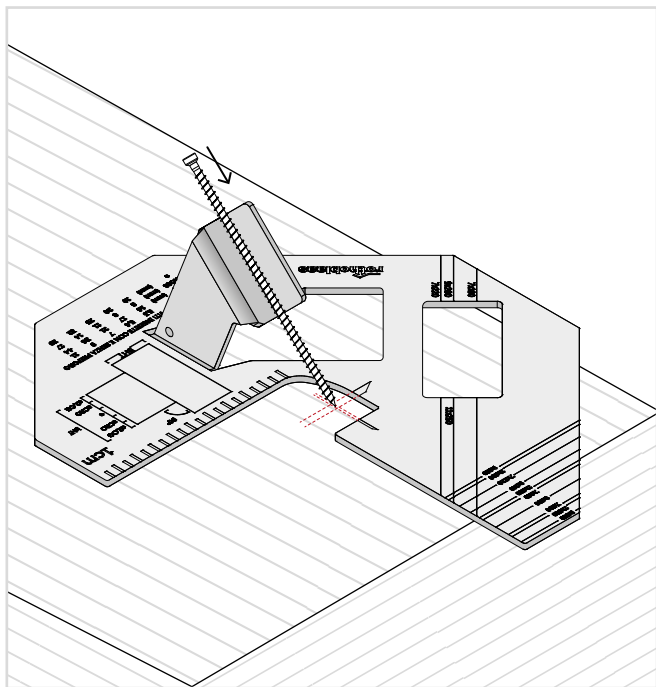
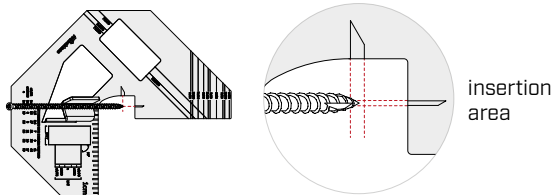

MINIMUM DISTANCE a_{2CG}

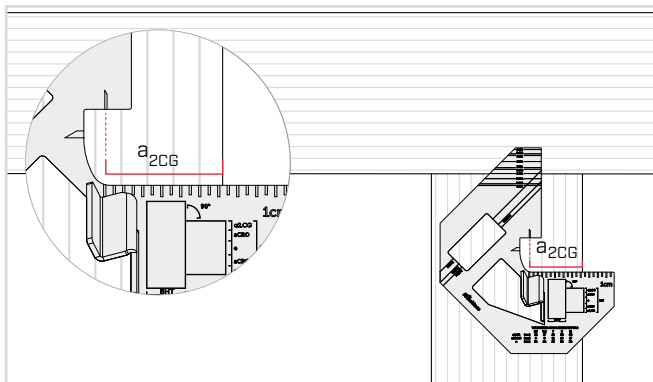

MINIMUM DISTANCE BETWEEN SCREWS

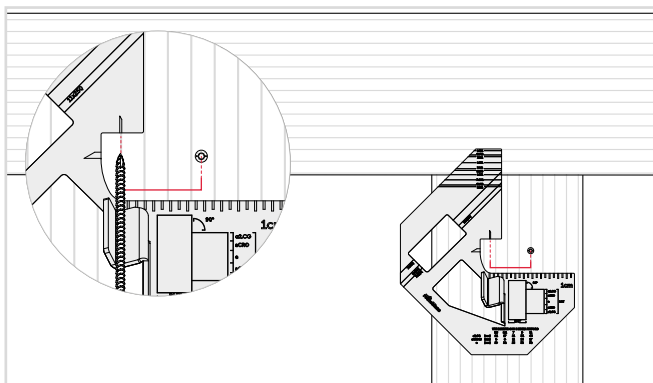

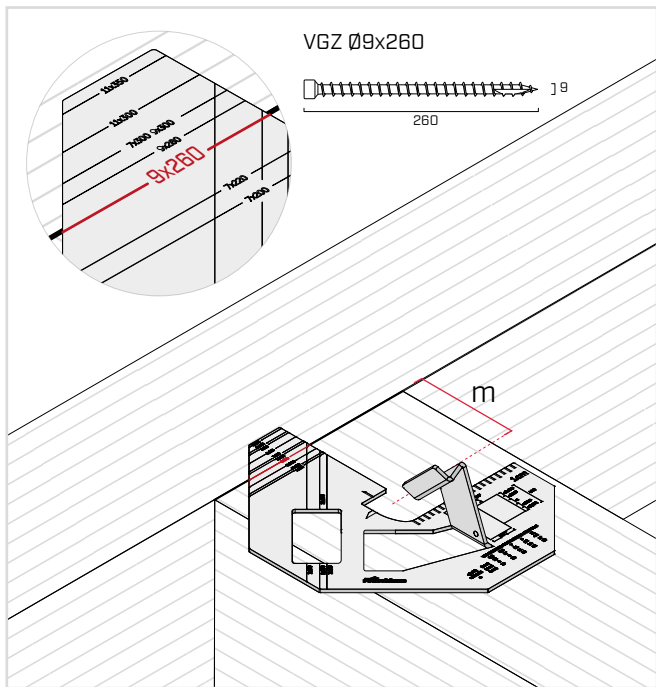
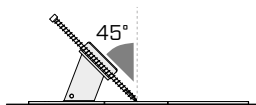
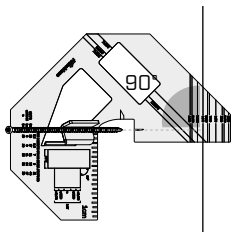

■ 45° + 45° ON THE RIGHT

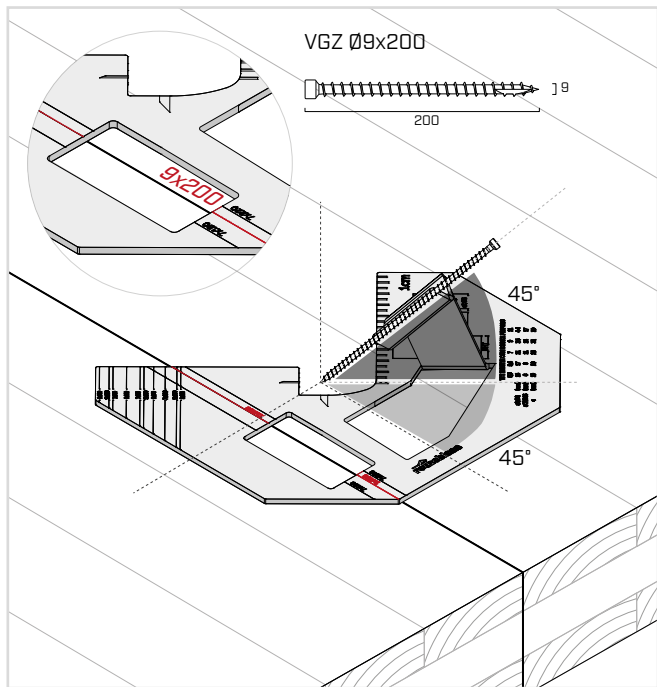
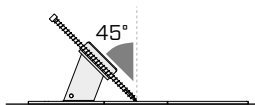
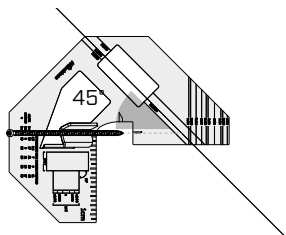

■ 45° + 45° ON THE LEFT

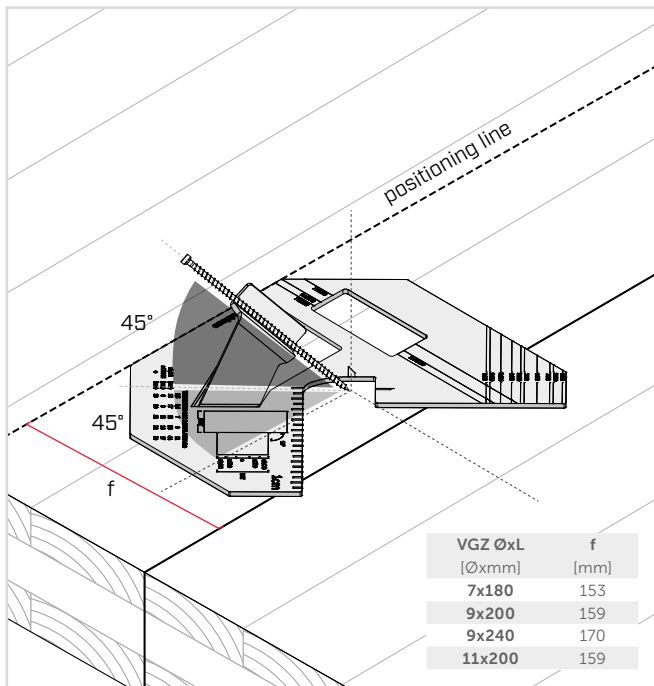
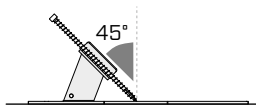
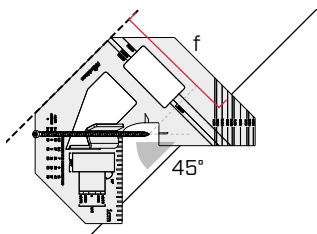

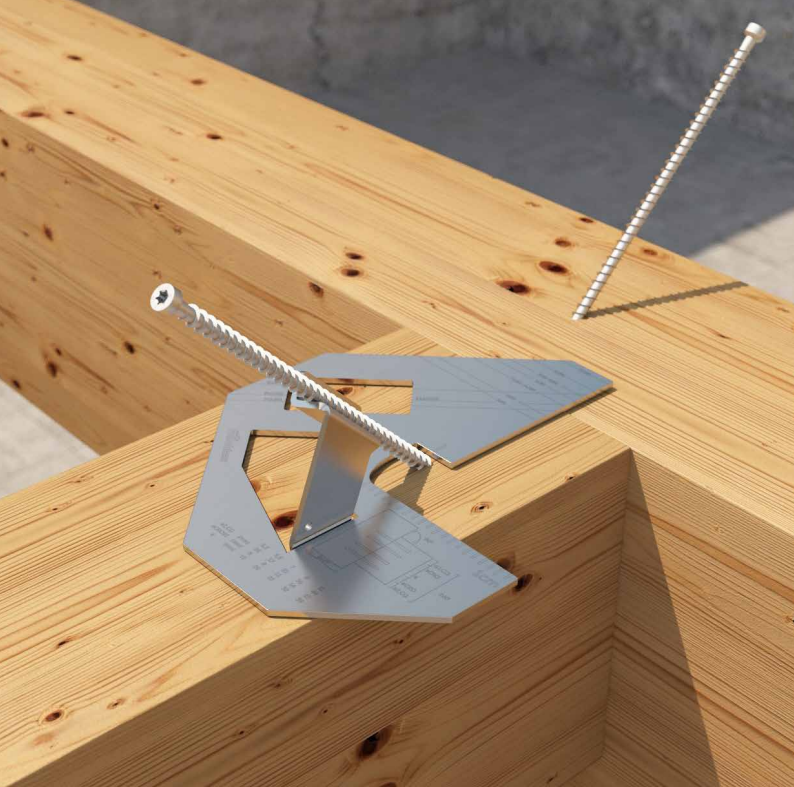

Rotho Blaas SRL

02|20

Via dell'Adige N.2/1 | 39040, Cortaccia (BZ) | Italia
Tel: +39 0471 81 84 00 | Fax: +39 0471 81 84 84
info@rothoblaas.com | www.rothoblaas.com

